



# ENTRY FORM

## DVASE 2019 Excellence in Structural Engineering Awards Program

### PROJECT CATEGORY (check one):

Buildings under \$5M		Buildings Over \$100M	X
Buildings \$5M-\$15M		Other Structures Under \$1M	
Buildings \$15M - \$40M		Other Structures Over \$1M	
Buildings \$40M - \$100M		Single Family Home	

Approximate construction cost of facility submitted:	\$200 Million
Name of Project:	Vantage
Location of Project:	Philadelphia, PA
Date construction was completed (M/Y):	Fall 2019
Structural Design Firm:	The Harman Group
Affiliation:	<b>All entries must be submitted by DVASE member firms or members.</b>
Architect:	Niles Bolton Associates, Inc.
General Contractor:	Intech Construction

Company Logo (insert .jpg in box below)



### Important Notes:

Please .pdf your completed entry form and email to [bsagusti@barrhorstman.com](mailto:bsagusti@barrhorstman.com).

Please also email separately 2-3 of the best .jpg images of your project, for the slide presentation at the May dinner and for the DVASE website. Include a brief (approx. 4 sentences) summary of the project for the DVASE Awards Presentation with this separate email.

Provide a concise project description in the following box (one page maximum). Include the significant aspects of the project and their relationship to the judging criteria.

Vantage is a 471,000 square foot mixed-use student housing building at the edge of the Temple University campus. Located on a 4.6-acre parcel that was the former site of John Wanamaker High School, Vantage is the second phase of The Goldenberg Group's redevelopment project. The project varies in height; portions of the project are 7, 12 and 19 stories, and includes one-to five-bedroom residential apartments; ground floor retail; amenities featuring a wellness and outdoor fitness center, a top-floor sky lounge and gated parking. This project also includes a 10,000 square foot innovation center for outreach programs and community support.

Vantage utilizes multiple structural systems. The 19-story East tower is structural steel and precast plank, while the West Tower is eight stories of precast plank and cold formed stud bearing walls over four stories of structural steel and concrete slabs on metal deck. The connector bridge unites the two towers with four stories of precast plank and cold formed stud bearing walls over three stories of structural steel and concrete slabs on metal deck.

#### **Creativity & Innovation for Efficiency**

The East Tower exterior columns are braced with a unique plank detail that eliminates 13 structural steel beams over 17 levels of the tower. Exterior columns are braced at each level in two directions. Spandrel beams brace the columns parallel to the slab edge, and the plank detail below provides bracing perpendicular to the slab edge while eliminating steel beams, connections, spray fire proofing, web penetrations and soffits.

Late in the design process, the client added floor to ceiling glass exterior walls to the West Tower and Bridge— including load bearing walls. The traditional cold formed load bearing walls were changed to a Special Bearing Wall of steel posts and beams. This allowed the design to continue as a load bearing wall system without impacting the schedule, and at the same time realizing the floor-to-ceiling exterior glass walls the client wanted.

Interdisciplinary collaboration was accelerated using online Bluebeam Sessions within existing software for live communication with the remote client. PDF markups of drawings for coordination were consolidated in the cloud, reducing the number of emails between project team members, memorializing design decisions with enhanced clarity and improving project data organization for all team members.

#### **Challenges & Complexity**

The West Tower and Bridge plank and bearing wall structure transfer at three different levels onto the supporting structural steel podium. This required careful coordination with the client and thorough detailing to ensure a complete load path to the foundation.

Interfaces of multiple façade systems including EIFS, Metal Panel, Window Wall, Curtainwall and Brick required careful coordination. Combine these different facades with exposed structural steel columns on East and West Towers as well as the Bridge, a sloped site, beam web penetrations for MEP, and braced frame columns with over 1600-kips of net uplift resulting in 18 sheets of structural non-typical details.

The following 5 pages (maximum) can be used to portray your project to the awards committee through photos, renderings, sketches, plans, etc.

East Tower exterior column bracing detail

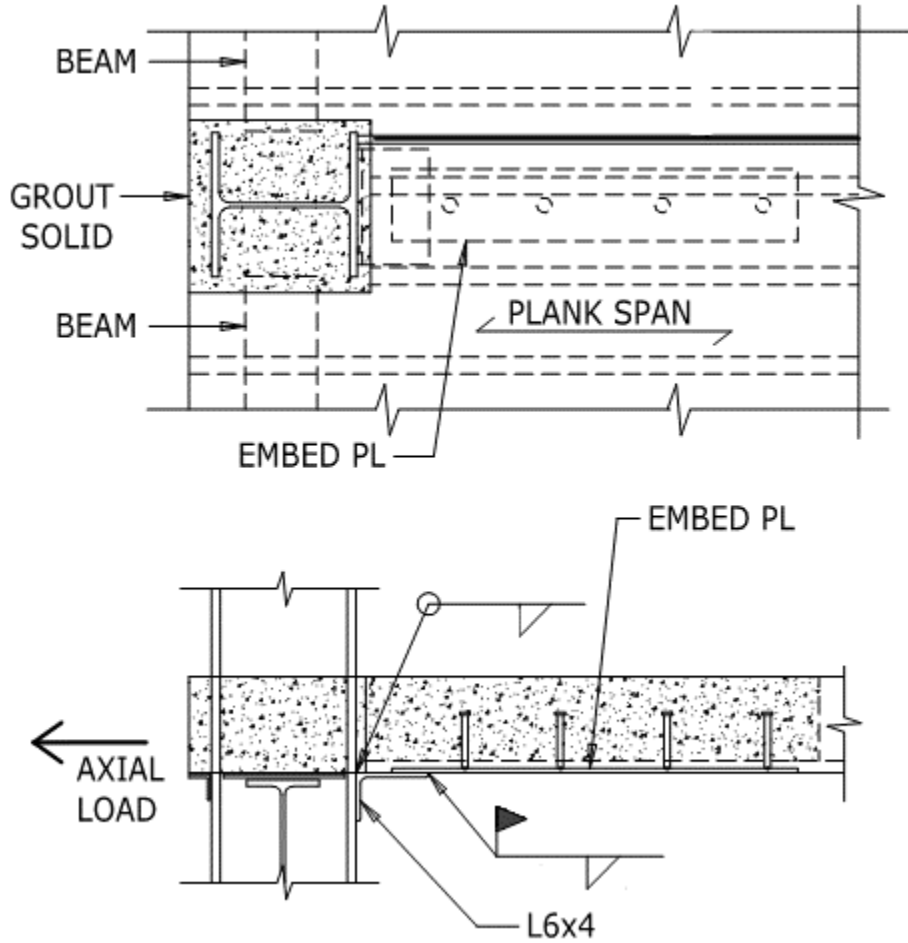

# West Tower and Bridge Special Bearing Wall at Floor-to-Ceiling Glass Walls

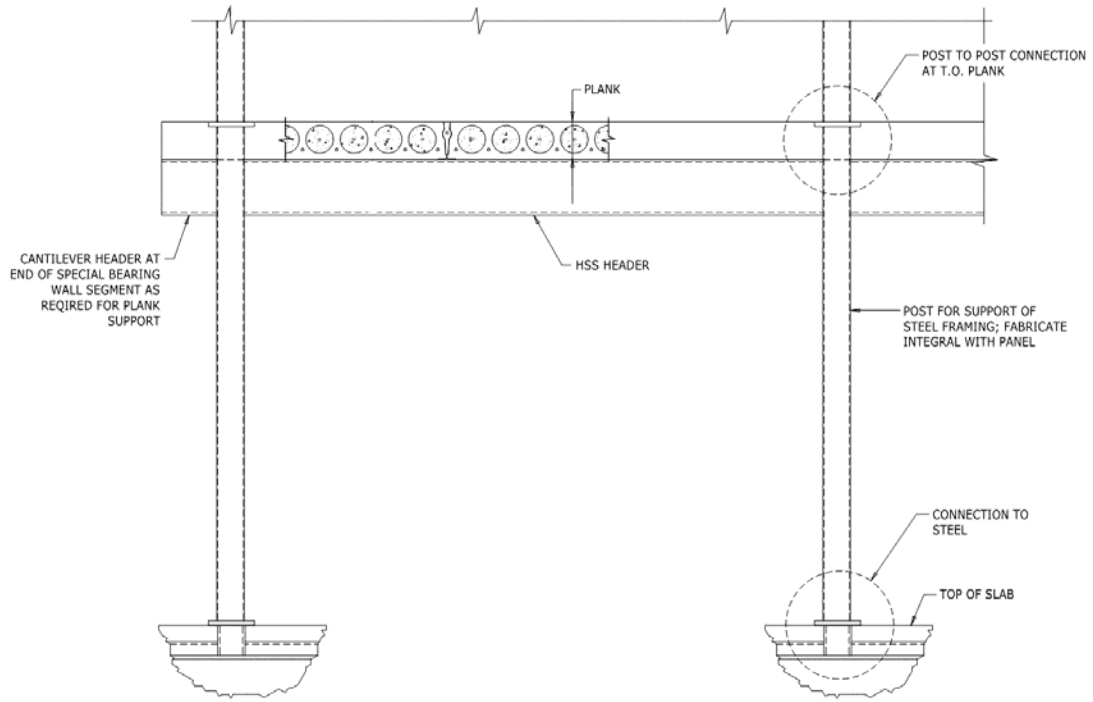

(Left side of photo below)



# High Uplift Column Baseplate Details

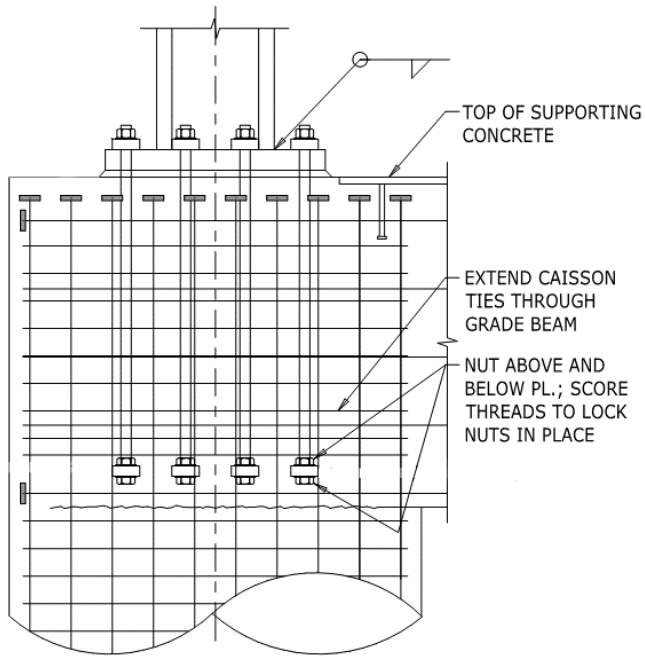
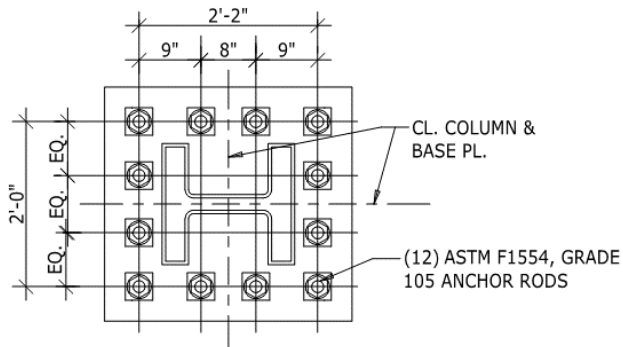

6<sup>th</sup> Floor Level Transfer Framing above 5<sup>th</sup> Floor Primary Transfer Level with exposed columns against curtainwall façade





By signing, signatory agrees to the following and represents that he or she is authorized to sign for the structural design firm of record:

*All entries become the property of DVASE and will not be returned. By entering, the entrant grants a royalty-free license is granted to DVASE to use any copyrighted material submitted.*

*If selected as an award winner, you may be offered the opportunity to present your project at a DVASE breakfast seminar. Would you be willing to present to your colleagues?*       **YES**      **NO**

Submitted by:

<b>Print name:</b> Malcolm Bland	<b>Signature:</b> 	<b>Date:</b> 3/22/19
<b>Submitting Firm:</b>	The Harman Group	
<b>Mailing address:</b>	900 West Valley Forge Road, Suite 200 King of Prussia, PA 19406	
<b>Telephone:</b> 610-337-3360	<b>Fax:</b> 610-337-3359	<b>Email:</b> mbland@harmangroup.com