

ENTRY FORM



DVASE 2021 Excellence in Structural Engineering Awards Program

PROJECT CATEGORY (check one):

Buildings under \$5M	X	Buildings Over \$100M	
Buildings \$5M - \$15M		Other Structures Under \$1M	
Buildings \$15M - \$40M		Other Structures Over \$1M	
Buildings \$40M - \$100M		Single Family Home	

Approximate construction cost of facility submitted:	\$660,000
Name of Project:	Uncommon School 571 18th Avenue School
Location of Project:	Newark, NJ
Date construction was completed (M/Y):	September 2019
Structural Design Firm:	Joseph B. Callaghan, Inc.
Affiliation:	All entries must be submitted by DVASE member firms or members.
Architect:	KSS Architects
General Contractor:	Phelps Construction Group

Company Logo (insert .jpg in box below)

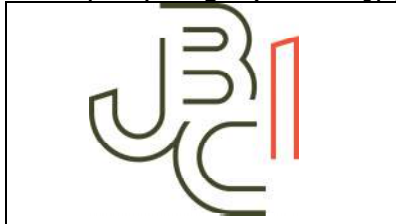

Important Notes:

- Please .pdf your completed entry form and email to bsagusti@barrhorstman.com.
- Please also email separately 2-3 of the best .jpg images of your project, for the slide presentation at the annual virtual presentation and for the DVASE website. Include a brief (approx. 4 sentences) summary of the project for the DVASE Awards Presentation with this separate email.

- Provide a concise project description in the following box (one page maximum). Include the significant aspects of the project and their relationship to the judging criteria.

At the intersection of 16th Street and 18th Avenue in Newark, New Jersey, was a collection of vacant structures, including two connected concrete-framed buildings – one 2-story and one 4-story. The buildings, used for manufacturing, are believed to have been built in the 1920s. The goal was to rehabilitate the existing 2- and 4-story buildings, add two additional floors to the 2-story building, and demolish three smaller structures on the site to allow for a large new addition, transforming the dilapidated property into a new school.

The structure consisted of a two-way concrete slab, spanning to 22" x 12" concrete beams, supported by 28" square concrete columns in a 19' x 15' grid. The buildings also boasted some interesting design elements including rectangular columns with spiral reinforcing, upturned beams, and a cast-in-place concrete cornice.

JBCI joined the design team as façade consultant for the existing concrete framed buildings. The perimeter concrete structure was in extensive disrepair. Decades of improper patch repairs and coatings trapped moisture and accelerated deterioration. A visual survey revealed large areas of missing concrete cover, exposed reinforcing steel, and failing previous repairs. In some cases, it was clear the structural integrity was compromised. It became clear that practically every single beam and column would require repair.

We created design documents to address ten different concrete repair types for isolated areas of corroded reinforcing steel and concrete cover. Complemented with projected repair quantities based on previous observations, the repair details included typical concrete beam and column repairs along with some unique details – repair of the concrete cornice that had spalled off in large sections, and repair of a spiral reinforced column where the concrete cover had completely fallen off.

When demolition began, it quickly became clear that the damage was far worse than the design team had anticipated. It also became clear that the condition of each concrete beam was unique, and each beam required a combination of multiple repair details. It was important that we evaluate each beam, developing a spreadsheet to track the status, repair type and quantity at each step of the repair process before we could authorize it to be formed and repaired.

Once the smaller adjacent buildings were demolished to fully expose the south elevation, we determined the concrete frame on that wall was beyond repair. Since the entire south elevation was to become an interior wall, the Structural Engineer of Record designed a new steel frame to bypass the existing concrete structure. We refocused our efforts to the street elevations, where it was crucial the original appearance of the building be restored. By the time demolition progressed to the street elevations, cold weather had arrived, and the entire area had to be tented to protect the construction.

As deteriorated concrete and old patch repairs were removed, we observed very wet underlying sound concrete, confirming moisture was being trapped beneath previous repair layers. The concrete had to dry out before beginning repairs. More surprises were in store:

- The structural engineer identified four spandrel beams where the slab had completely broken free from the beam. In some locations it had dropped 1½", compromising the original two-way slab action. We collaborated with the structural engineer to design a new repair detail to reattach the beams to the slab.
- At some locations, deterioration had progressed so far that the reinforcing steel cage was completely gone due to corrosion – we were not simply replacing the concrete cover, we were replacing structural concrete. We redesigned the beam with a new reinforcing cage, and our patching material changed from a repair mortar to a structural concrete mix.
- At another location, demolition progressed so far that the section area at the center of the beam had almost been reduced to zero – at this point we recommended a full replacement.
- Finally, a section of the concrete cornice had cracked and separated from the beam inside the wall – so we designed a repair to stabilize it in place.

By the following spring and summer, new windows were installed as concrete repair efforts were substantially complete. By fall, the new addition was complete and the concrete had been coated. This project was a true learning experience for our firm. It was the most severe and widespread structural concrete deterioration we had seen and was far worse than could have been determined without extensive destructive investigation of each and every beam and column. Overall, it was a rewarding and creative experience and a fantastic transformation!

- The following 5 pages (maximum) can be used to portray your project to the awards committee through photos, renderings, sketches, plans, etc...





571 18th Avenue Concrete Repair Progress				
		Repair Status		
Elevation	Beam	Concrete Demolition	Rebar & Anode Placement	Coat Reinf. & Patch
North	N-A1	Complete	Ready	Not Permitted
	N-A2	Complete	Ready	Not Permitted
	N-A3	Not Yet Started	Not ready	Not Permitted
	N-A4	Incomplete	Not ready	Not Permitted
	N-B1	Incomplete	Not ready	Not Permitted
	N-B2	Complete	Ready	Not Permitted
	N-B3	Incomplete	Not ready	Not Permitted
	N-B4	Incomplete	Not ready	Not Permitted

		Repair Type					
Elevation	Beam	1 (LF)	2 (LF)	3 (LF)	4 (LF)	5 (SF)	
North	N-A1		8		2		
	N-A2				10		
	N-A3						
	N-A4		9				
	N-B1		10	10			
	N-B2			10	10		
	N-B3						
	N-B4		3			1	
Total Quantities		0	0	89	82	126	3
Bid Quantities		0	125	175	175	225	75
Remaining Balance		0	125	86	93	99	72

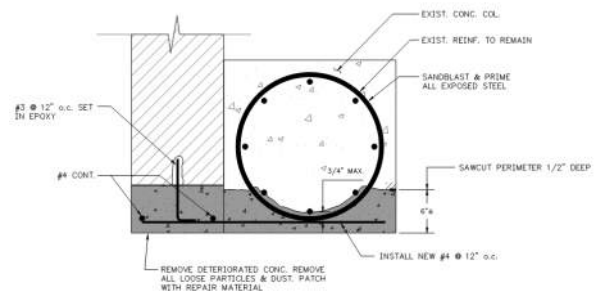
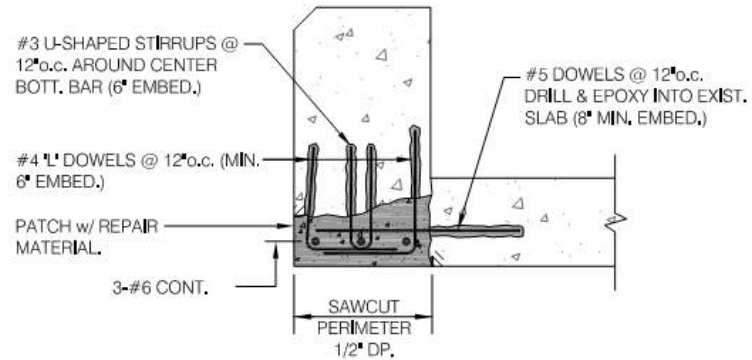
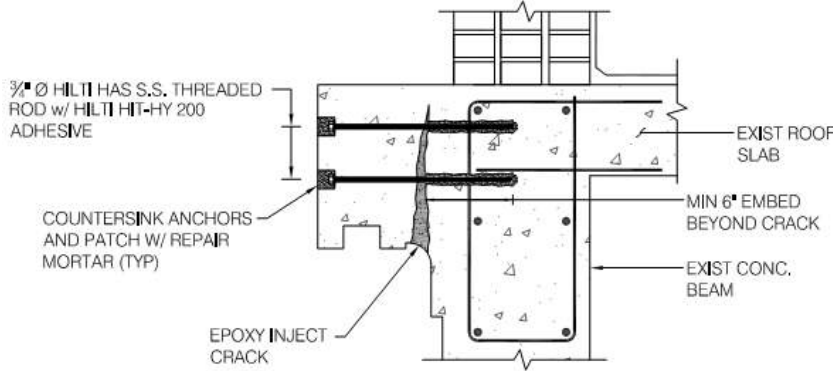
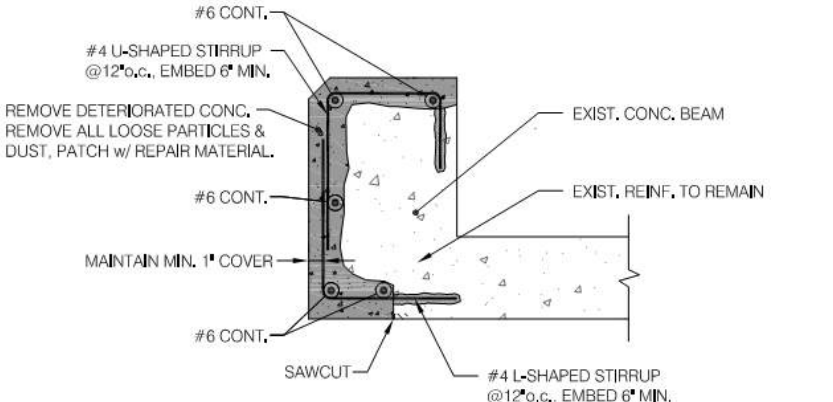





By signing, signatory agrees to the following and represents that he or she is authorized to sign for the structural design firm of record.

All entries become the property of DVASE and will not be returned. By entering, the entrant grants a royalty-free license to DVASE to use any copyrighted material submitted.

If selected as an award winner, you may be offered the opportunity to present your project at a DVASE breakfast seminar. Would you be willing to present to your colleagues? **YES** **NO**

Submitted by:

Print name: Jessica Clifford, PE	Signature: 	Date: 3.36.21
Submitting Firm:	Joseph B. Callaghan, Inc.	
Mailing address:	1617 John F. Kennedy Blvd., Suite 1655 Philadelphia, PA 19103	
Telephone: 215.665.0497	Fax: 215.665.1345	Email: jclifford@jbciengineers.com